

**SUPERHEATED WATER BOILER, THREE PASS REVERSE FLAME,
AT MEDIUM AND HIGH PRESSURE - 90% EFFICIENCY**

OUTPUT RANGE	from 140 to 2900 kW						
TYPE	OR						
	smooth pipe						
FUEL	gas, light & heavy oil						
WORKING PRESSURE	4.9 bar (SÜHR' 5) / 9.8 bar (SÜHR' 10)						
WORKING TEMPERATURE	158.1°C (SÜHR' 5) / 183.2°C (SÜHR' 10)						
MODELS	140	210	270	370	465	580	700
	1000	1160	1400	1750	2050	2300	2900

DESCRIPTION

Superheated water boiler, three pass reversed flame, smooth pipes with turbulators, 90% efficiency ⁽¹⁾.

MATS is a family of packaged smoke tube superheated water boilers, three pass reversed flame, wet back. Standard safety pressure up to 5 bar (mats 5) or 10 bar (mats 10), higher pressure available on request, and output from 140 to 2900 kW. It can be operated with liquid or gaseous fuels. Every model is complete with regulations and safety accessories for automatic operation and easy commissioning.

In compliance to the current laws, each superheated boiler undergoes a conformity assessment, carried out by a Notified Body.

The conformance to the essential safety requirements demanded by the European Pressure Equipment Directive 2014/68/UE (PED) is guaranteed by the CE mark.

Design features:

By means of the reverse flame principle the smoke gases in the combustion chamber are diverted to the front, then reversed again to the smoke tube sections and discharged through the chimney connection. The appliance is designed to ensure low heating loads in the combustion chamber and low superficial loads.

- **Boiler body:** is made up of a cylindrical shell and a wet back furnace, made of high quality steel. All the materials have certificates attesting their chemical and mechanical characteristics, the controls are carried out during each production stage, and, theirs suitability for use as well. The welding seams are carried out by qualified personnel in compliance to certified procedures and are subjected to Non Destructive Tests, in accordance to an internal "Manufacturing and Control" program. Once the boilers have been manufactured they are subjected to hydraulic testing in accordance to the requirement 7.4 – Annex I, laid down in the Directive 2014/68/UE (PED).
- **Smoke tubes:** made of high quality steel, are welded to tube plates. Pipes are equipped with helical turbulators.
- **Front door:** is built in welded steel plate, completely cladded internally with a layer of insulation material and with a layer of high density refractory material. The door is fitted with hinges which enable it to be easily adjusted and quickly opened. Moreover, the door is fitted with a self-cleaning sight glass for combustion control during boiler operation.

- **Rear smoke-box:** is built in welded steel plate and fixed on to the tube plate by nuts for an easy access to it. It is fitted with a small door for cleaning purposes and the horizontal flue connection (vertical on request), with a diameter sized to the boiler's output. The rear smoke-box can be accessorized with and external economizer.
- **Basement:** is built with a steel frame, welded to the tube plates and closed with steel plates.
- **Insulation:** the shell is thermally insulated with rock wool cladding, suitably supported and covered externally in 10/10 thick enamelled aluminum.

Standard equipment: ⁽²⁾

- n. 1 or 2 spring loaded safety valves (according boiler's capacity).
- n. 1 manual draining group.
- Control board panel complete with:
 - n. 1 thermometer
 - n. 2 working thermostats
 - n. 1 safety thermostat with manual reset
 - n. 1 manometer
 - n. 1 safety pressure switch with manual reset.
- Blind burner plate.
- Carbon steel turbulators.
- Lifting lugs.
- Document folder enclosing:
 - Manufacturer's Declaration of Conformity in compliance with the Annex VII of the European Directive 2014/68/UE (PED)
 - Installation, operation and service manuals.
 - Certificates of safety components.
 - Control board's electric schemes and related Declaration of Conformity.
 - Water characteristics: requirements concerning the quality of water supply, the water in the boiler, frequency and type of sample tests to do.

(1) This value is intended without economizer and may change according working pressure and load conditions.

(2) The quantity and the model may vary according to the configuration.

MAIN COMPONENTS

1. Boiler body
2. Front door
3. Rear smoke chamber
4. Board panel
5. Man hole for inspection
6. Safety pressure switch
7. Manometer with 3 way cock for calibration purposes
8. Safety valves
- T1. Flow
- T2. Return
- T3. Boiler drain
- T4. Chimney connection

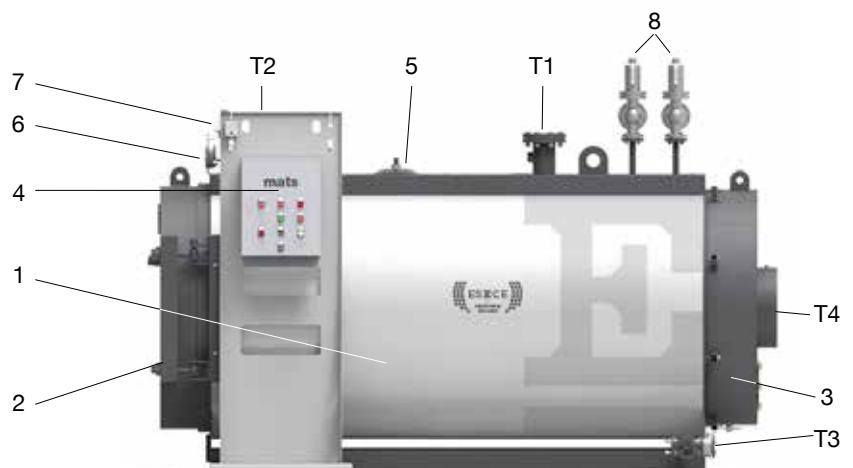

TECHNICAL DATA

Model	Nominal output	Nominal input	ΔP smoke side	Water content	Water side pressure drop (ΔT 15°C)	Empty weight mats 5 bar	Empty weight mats 10 bar
	kW	kW	mbar	l	mbar	kg	kg
140	140	157	2.0	335	3.7	765	930
210	210	223	2.5	549	8	1090	1330
270	268	300	3.0	549	13	1090	1330
370	372	418	4.2	690	11	1550	1890
465	465	523	4.5	690	17	1550	1890
580	581.5	653	5.0	1143	12	1690	2060
700	700	784	6.0	1143	18	2080	2540
1000	1000	1125	7.0	1625	22	2595	3165
1160	1160	1289	5.5	1625	20	2595	3165
1400	1395	1567	6.0	1950	22	3220	3930
1750	1745	1960	7.0	2575	25	4730	5770
2050	2035	2287	8.2	2575	30	4730	5770
2300	2325	2613	9.0	3015	40	5795	7070
2900	2900	3223	9.5	4290	45	6910	8430

DIMENSIONS

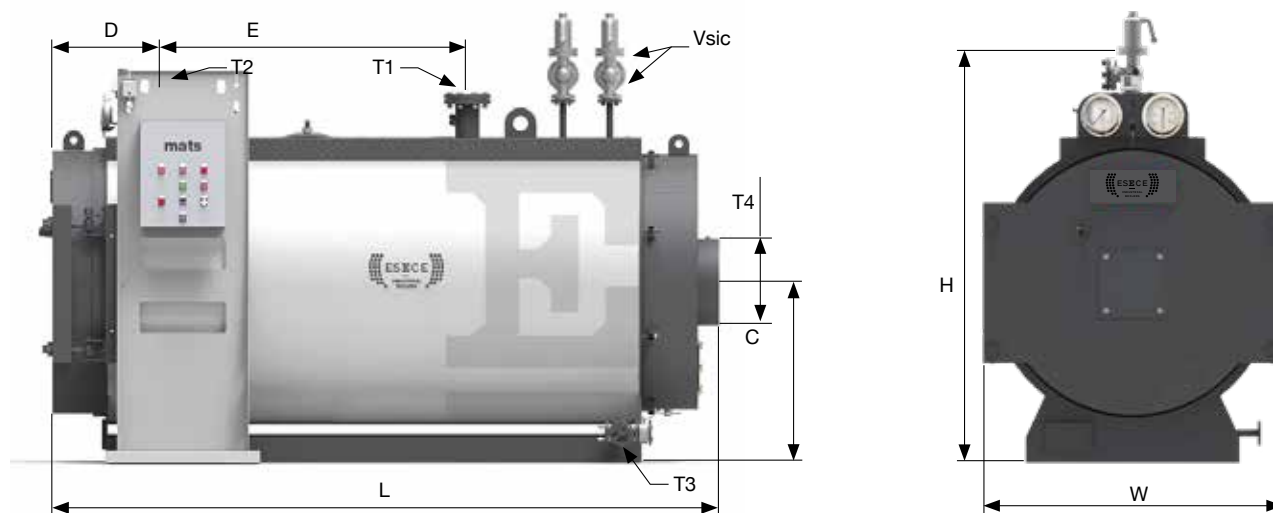

Model	W	L	H	C	D	E	T1 - T2	T3	T4	Vsic
	mm	mm	mm	mm	mm	mm	DN	DN	Øi mm	DN
140	900	1900	1230	550	200	650	65	25	202	20/32
210	1000	2125	1270	600	200	800	65	25	222	20/40
270	1000	2125	1270	600	200	800	65	25	222	20/40
370	1115	2424	1327	675	200	1010	80	25	252	20/40
465	1115	2424	1327	675	200	1010	80	25	252	20/40
580	1270	2792	1500	765	200	1140	80	25	352	20/40
700	1270	2792	1500	765	200	1140	80	25	352	20/40
1000	1400	3200	1660	865	250	1450	100	25	402	25/40
1160	1400	3200	1660	865	250	1450	100	25	402	25/40
1400	1510	3426	1770	920	300	1570	125	25	402	40/50
1750	1720	3500	2030	1075	300	1600	150	40	502	40/50
2050	1720	3500	2030	1075	300	1600	150	40	502	40/50
2300	1800	3875	2120	1115	300	1700	150	40	552	40/50
2900	1980	4195	2290	1205	300	1850	200	40	602	40/65

PRODUCT PLUS VALUES

■ FRONT DOOR

Fitted on hinges, with reversible opening. It is in welded steel sheet, with the inside completely insulated with refractory concrete. Complete with burner plate and flame sight glass

■ REAR SMOKE CHAMBER

Made of steel sheet and complete of horizontal chimney connection (vertical on request) and cleaning openings

■ BASEMENT

In steel profiles

■ THERMAL INSULATION

Made of a mineral wool mattress, externally protected by painted aluminum panels

■ DELIVERY

Is complete with board panel "FLAT_SH", safety and control devices

STANDARD-PRODUCTION EQUIPMENT

■ Insulation with aluminum cladding

■ Turbulators

■ Spring actuated safety valve(s)

■ Manual draining group

■ N. 1 dial type thermometer

■ N. 1 dial type manometer with 3 way cock for calibration purposes

■ N. 2 working thermostats

■ N. 1 manual reset safety thermostat

■ N. 1 manual reset safety pressure switch

BOARD PANELS (optional)

IMC_SH

- Single and two-stage burner control
- Possible 24/72 h exemption
- No. 1 low level safety PED level switch (optional)
- Terminal board on quick coupling connectors
- Expansion with optional kits
- IP55 Protection rating



IML_SH

- Control PLC
- 7" touch screen display with graphic interface
- Single and two-stage, three-stage, modulating burner control
- Possible 24/72 h exemption
- No. 1 low level safety PED level switch (optional)
- Terminal board on quick coupling connectors
- Expansion with optional kits
- IP55 Protection rating



OPTIONAL EQUIPMENT

■ 24 h EXEMPTION KIT

Set of accessories to obtain the partial exemption of the burner (24 h) according to L.D. 25 February 2000 no.93, MD 1 December 2004, no.329, UNI/T S 11325-3:2010.

Consisting of:

- 24h exemption control panel including a timer and preset for a 24h exemption reset procedure
- Instrument/safety device wood log to be mounted on the boiler flow, with all equipment required and namely:
 - 1 pressure gauge with a pressure gauge valve
 - 1 large dial thermometer with a limit indication
 - 1 maximum and minimum safety pressure switch
 - 1 reflection level indicator with shut-off valves
 - 1 fail-safe minimum level safety probe
 - 2 fail-safe self-controlled temperature switch units (PT100), TRD604 CAT. IV.



■ 72 h EXEMPTION KIT

Set of accessories to obtain the partial exemption of the burner (72 h) according to L.D. 25 February 2000 no.93, MD 1 December 2004, no.329, UNI/T S 11325-3:2010.

Consisting of:

- Control panel for up to a 72h exemption, including a timer and preset for a 72h exemption reset procedure
- Instrument/safety device wood log to be mounted on the boiler flow, with all equipment required and namely:
 - 1 pressure gauge with a pressure gauge valve
 - 1 large dial thermometer with a limit indication
 - 1 maximum and minimum safety pressure switch
 - 1 reflection level indicator with shut-off valves
 - 1 fail-safe minimum level safety probe
 - 2 fail-safe self-controlled temperature switch units (PT100), TRD604 CAT. IV.
- 1 kit of safety accessories for the expansion vessel consisting of a minimum pressure switch and fail-safe minimum level safety probe